

Online Trace Gas Analyzer

ATQ3000

Feature:

- Patent No.: ZL201410411351.1, ZL201420471113.5
- Gases measured: CH₄, NO, NO₂, CO, H₂S, O₂, H₂O, CO₂, NH₃, ¹³C/¹²C, ¹⁵N/¹⁴N, SO₂, NO_x, CO, O₃, PM10 etc.
- Principle: Spectral Absorbance
- High-Precision reach down to minimum ppb-class;
- Long Optical Path reach up to maximum 15 m;
- Core modular size: 0.36×0.13×0.18 m³;
- Self-Check Function of Light Source Intensity;
- High Responsivity, Repeatability, Accuracy, Convenience
- Standard 19" case

Application:

- Air measurement;
- Monitor gases of H₂S, H₂O;
- Online monitor exhaust gases;
- Online monitor industrial combustion O₂;
- Automobile exhaust gases;

Description:

ATQ3000 is self-designed trace gas analyzer base on the gas molecule absorbance in the range of NIR/Mid-IR. The measured relationship base on Beer-Lambert Law, say infrared light attenuation in direct proportion to gas concentration and optical length. The infrared light in specific range decided by the detected gas, go through collimating, commissioning through high speed chopper, shoot through the gas cell with the customized multi-harmonic ring-down cavity, the incident laser reflected to and pro the measured cell, and final emitted through emission port, reach to optical-electric test device and circuit board, light intensity emitted divided by incident intensity can calculate the infrared light attenuation, considering optical length is given, gas concentration can be further calculated.

This product applied patent ZL201410411351.1, ZL201420471113.5. In the condition of small size gas cell can use multi-ring-down to make multiple reflectance, the effective optical range increased by about 1000 times, and results in high accurate measured results. The unique long optical length gas cell usually applied to spectral analysis. Considering compact size, easy-to-install and operate, it applied to laboratory trace gas analysis, industrial process measure, environmental industry for gas detection, biochemical and biomedical spectrum analysis.



Fig 1 ATQ3000 Gas Analyzer
(Customized Case Outlook)



Fig 2 Gas Measurement Principle
(Patent: ZL201410411351.1, ZL201420471113.5)

ATQ3000 is self-designed trace gas analyzer base on the gas molecule absorbance in the range of NIR/Mid-IR. The measured relationship base on Beer-Lambert Law, say infrared light attenuation in direct proportion to gas concentration and optical length. The infrared light in specific range decided by the detected gas, go through collimating, commissioning through high speed chopper, shoot through the gas cell with the customized multi-harmonic ring-down cavity, the incident laser reflected to and pro the measured cell, and final emitted through emission port, reach to optical-electric test device and circuit board, light intensity emitted divided by incident intensity can calculate the infrared light attenuation, considering optical length is given, gas concentration can be further calculated.

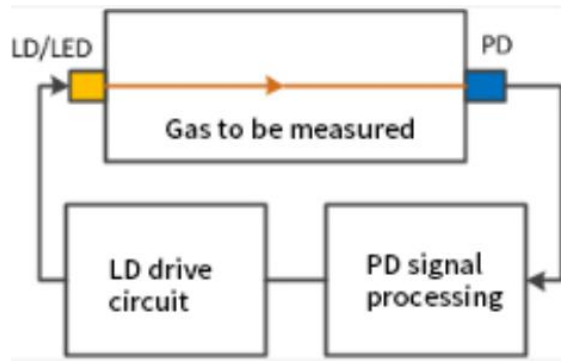

Fig 3 Gas Absorbance Beer-Lambert Law

This product applied patent ZL201410411351.1, ZL201420471113.5. In the condition of small size gas cell can use multi-ring-down to make multiple reflectance, the effective optical range increased by about 1000 times, and results in high accurate measured results. The unique long optical length gas cell usually applied to spectral analysis. Considering compact size, easy-to-install and operate, it applied to laboratory trace gas analysis, industrial process measure, environmental industry for gas detection, biochemical and biomedical spectrum analysis.

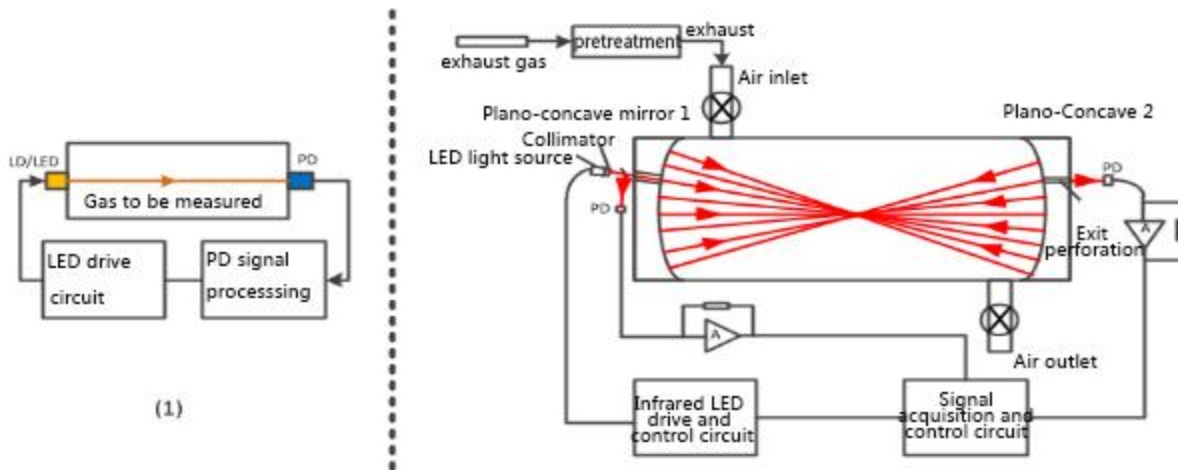

Fig 4 The left is one optical range gas cell, the right is multi-harmonic ring-down cavity technology (Patent technology: ZL201410411351.1,ZL201420471113.5)

2.

Gases	Sensitivity	Range
CH4	5 ppb	0 ~ 2000 ppm
NO	1 ppb	0 ~ 2000 ppm
CO	1 ppb	0 ~ 2000 ppm
H2S	10 ppb	0 ~ 2000 ppm
O2	100 ppb	0 ~ 20%
H2O	1 ppb	0 ~ 2000 ppm
CO2	2 ppb	0 ~ 80%
NH3	5 ppb	0 ~ 2000 ppm
13C/12C	<1‰	TBD
15N/14N	<1‰	TBD
SO2	10 ppb	0 ~ 2000 ppm
NOx	10 ppb	0 ~ 2000 ppm
O3	10 ppb	0 ~ 2000 ppm
PM10	TBD	TBD

3、Performance Configuration

System	
Interface	RS485, LAN
Storage Space	8 GB
Power supply	100 ~ 265V, 50/60Hz,
Power	<50W
Dimension	1.2×0.6×0.6 m3 (Customized case size)
Weight	54.5 Kg
Reliability	
Operating Temp Range	0 ~ 40°C
Storage Temp Range	-20 ~ 65°C
Operating Humidity Range	< 85% RH
Modular	
Dimension	0.36×0.13×0.18 m3
Effective Optical Path	<15 m
Light Source	NIR/MID-Laser differ to gases measured
Detector	InGaAs/PbS/HgCdTe
Power Supply	+24V, 2A

4. Application examples

4.1 Online monitoring of industrial combustion oxygen content

During industrial combustion, During industrial combustion, Real-time monitoring of the oxygen content in the boiler process gas is required to accurately control the input fuel/oxygen ratio to achieve the goals of complete combustion, explosion-proof safety, pollution prevention, and improvement of steelmaking quality. Compared with the traditional zirconia sensing technology, the boiler residual oxygen monitoring program produced by our company has a series of advantages such as high sensitivity, resistance to water vapor interference, resistance to dust pollution, no consumables, and no maintenance.



Figure 5 Online monitoring of industrial combustion oxygen content

4.2 Monitoring of trace CO₂, H₂S, H₂O in natural gas

In the process of natural gas production and transportation, the impurity components of natural gas such as CO₂, H₂S and other acid gases and water molecules must be effectively removed to avoid corrosion damage to pipeline containers and ensure the quality of energy products. The company's high-precision gas analyzer can realize simultaneous monitoring of multi-component gases in a shared optical path, and is especially suitable for quality monitoring of multi-component impurities in natural gas.

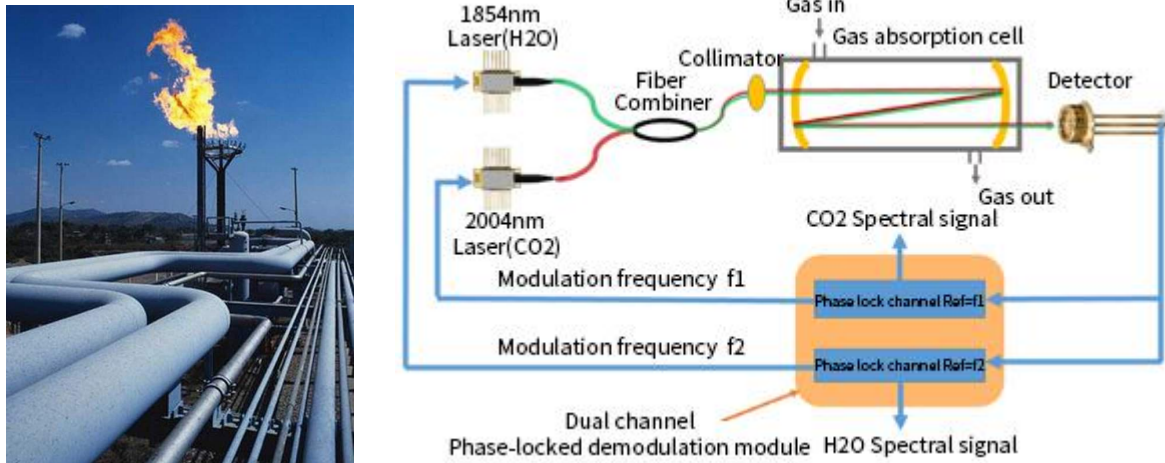

Figure 6 Multi-component simultaneous online monitoring scheme of shared optical path system

4.3 Automobile exhaust gas measurement

Automobile exhaust gas analyzer is an instrument used to detect the content of various gas elements in automobile exhaust. The automobile exhaust gas analyzer uses non-dispersive infrared and electrochemical sensors to measure and analyze the main components CO, HC, CO₂, NOX and O₂ in automobile exhaust. Development, production and verification according to the requirements of ISO9001 quality assurance system and JJG688-90 verification regulations. In the development process, the suggestions of many environmental protection experts and automobile manufacturers and maintenance manufacturers have been adopted, and it is completely suitable for environmental protection departments and vehicle maintenance, security inspections, road inspections and other automobile exhaust emission detection occasions. It has good stability, high measurement accuracy and long service life.

1. Road inspection and random inspection by environmental monitoring department

By using car exhaust, inspectors can carry out random inspections of vehicles on the road anywhere with the car, without being affected by objective conditions such as weather. The labor intensity of inspectors can also be improved.

2. Quick inspection of exhaust gas purification device

Exhaust gas purification device inspection must be carried out under working conditions, but the current working condition test requires bench testing. The price ranges from 500,000 to 600,000 yuan, and as many

as several hundred to tens of millions. The cost is also great. Many production and research units do not have the ability to regularly test products. Due to the lightness of the car tail, it can be used to detect the actual road driving conditions of the car, and simply and conveniently reflect the basic exhaust emissions of the car in different loads and different roads. The cost is only a one-time investment of tens of thousands of yuan in equipment.

3. Research work on automobile exhaust

Using the characteristics of automobile exhaust gas detectors, researchers can easily obtain basic data on automobile exhaust emissions under different traffic conditions in the city, provide reference information for government decision-making agencies, and facilitate government decisions such as urban road planning and traffic management.

4. Auto repair shop

The operation of the automobile exhaust gas detector is very simple, and the maintenance workers only need a few hours of training to master it. The function of the automobile exhaust gas detector can not only be used for exhaust gas detection but also for the inspection of automobile combustion system failures, providing a fast and reliable reference for exhaust gas adjustment.

5. Reference calibration of other field instruments

Due to the portability of the automobile exhaust gas detector, managers can carry the instruments that have just been calibrated in the laboratory to inspect the operating conditions of the instruments in use in units such as annual inspection plants, repair shops, and exhaust gas treatment plants.



Figure 7 Automobile exhaust detection